

# INTEGRATED MOTOR

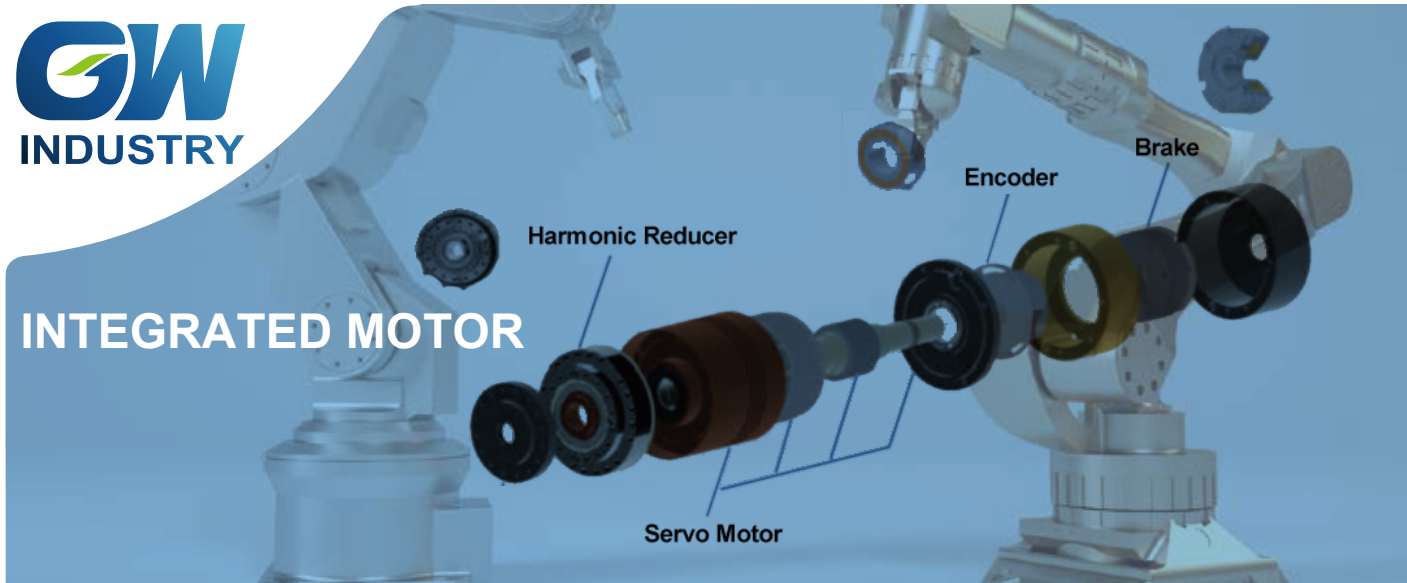

## Features :

- The integrated motor is a new type of drive unit which integrates servo motors, harmonic reducers, encoders and brakes.
- The integral motor shaft is hollow, from which the complicated control cable and screw can pass through. Small size, weight light , small torque ripple, high control precision, easy assembly.
- Apply to precision transmission systems such as robot joints, high-end CNC machine tools.



Parameter	Unit	SF50-14		SF140-17		SF210-20		SF310-25	
Voltage	V	220VAC/48VDC							
Output Power	W	50		140		210		310	
Reduction Ratio	-----	50	80	50	80	50	80	50	80
Peak Torque	Nm	28	38	56	70	78	102	31	51
Rated Torque	Nm	4.3	6.2	13	18	20	27	31	50
Rated Speed	rpm	60	37.5	60	37.5	60	37.5	60	37.5
Maximum Speed	rpm	100	62.5	100	62.5	100	62.5	100	62.5

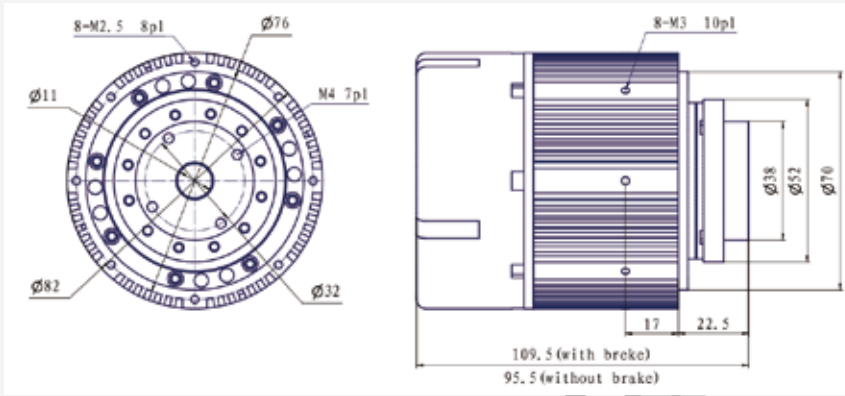

Figure.1 SF50-14 Motor's Dimension Drawing

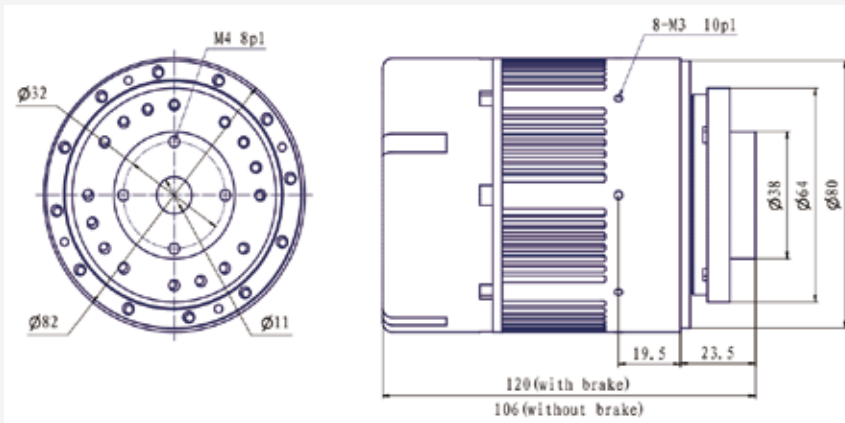

Figure.2 SF140-17 Motor's Dimension Drawing

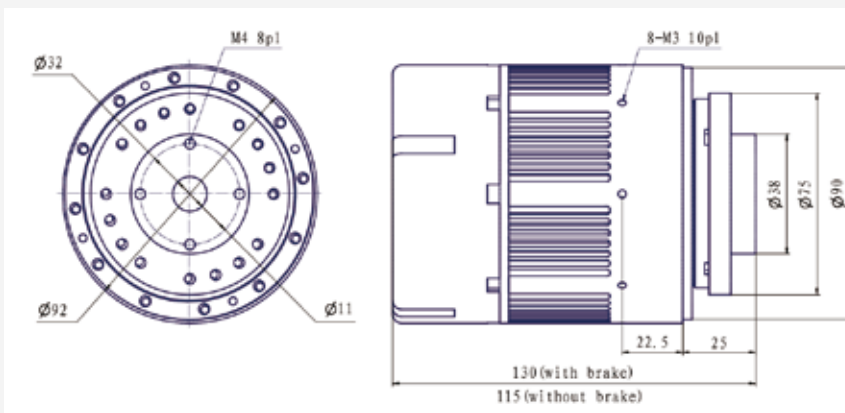

Figure.4 SF310-25 Motor's Dimension Drawing

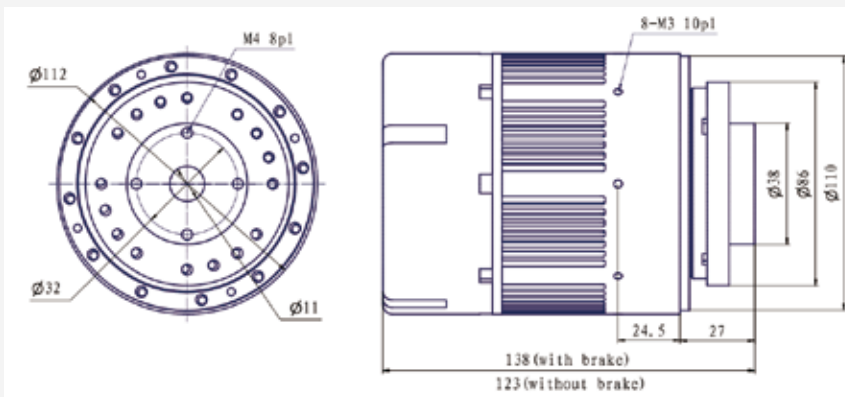

Figure.4 SF310-25 Motor's Dimension Drawing

\* The above data are for reference only and can be customized as required.