

应用场所 Application

- 广泛应用于海洋工程各类作业平台、各类化学品、天然气运输船、危险品码头等危险区域作远距离泛光照明之用；
- 可在潮湿、振动、腐蚀等恶劣环境中可靠工作；
- 适用于爆炸性危险环境1区、2区、21区、22区等场所。
- Widely used for floodlight illumination on various marine platforms, chemical tankers, LNG ships and hazardous cargo wharfs, etc..
- Can reliably work in severe environment exposed in moisture, vibration or corrosion;
- Explosive hazardous atmosphere Zone 1, Zone 2, Zone 21, Zone 22.



灯体 Housing

- 优质海工铝合金，表面喷塑
- High quality maritime aluminum alloy, powder coated surface

透明罩 Transparent cover

- 钢化玻璃，抗4J冲击
- Toughened glass, stands 4J impact

电气 Electric

- 电感镇流器
- Electromagnetic ballast

选配表 Selection table

型号 Type	额定电压(V) Rated voltage	额定功率(W) Rated power	灯座 Lamp holder	防爆标志 Ex-Mark	重量(kg) Weight
HRT53-L70	220V/230V AC	70W	E27	Ex d e IIC T4 Gb Ex tD A21 IP66 T130°C	7.1
HRT53-N70		70W			7.1
HRT53-L100		100W			7.1
HRT53-L150		150W			7.1
HRT53-N100		100W	E40	Ex d e IIC T4 Gb / Ex tD A21 IP66 T130°C	7.1
HRT53-N150		150W			14.3
HRT53-L250		250W			14.3
HRT53-N250		250W			14.3
HRT53-L400		400W			24.1
HRT53-N400		400W			24.1

- 本灯具出厂时不配光源，由用户自配，建议配置飞利浦、欧司朗、亚明品牌，金卤灯需配置欧标光源；
- 灯具出厂时配防爆堵头，若用户需要防爆电缆夹紧密封接头，请注明。
- The light source will be supplied by user, Philips, Osram, Yamin brands are recommended, metal halide lamp should be provided in compliance with European standard;
- The light fitting is supplied with Ex type stopping plug and Ex cable gland is on request.

技术参数 Technical parameters

执行标准 Conformity to standards	IEC60079, EN60079, GB3836, GB12476, CCS入级规范 (CCS standard)
环境温度 Ambient temperature	-25°C~+55°C
光源类型 Light source	金卤灯(L)、高压钠灯(N) Metal halide lamp (L), High-pressure sodium lamp (N)
防护等级 Degree of protection	IP66
防腐等级 Corrosion-proof	WF2
电缆入口 Cable entries	2 × M25 × 1.5堵头(铝合金), 推荐配2 × M25 × 1.5格兰(黄铜镀镍)DQM-II/III Exd, 适用于Φ12.5~Φ20.5mm电缆 2×M25×1.5 plug (Aluminum alloy), 2×M25×1.5 gland (Nickel plated brass) DQM-II/III Exd is recommended, suitable for Φ12.5-Φ20.5mm cable
接线端子 Terminal	3 × 1.5~4mm ²

外形尺寸 Outline dimension

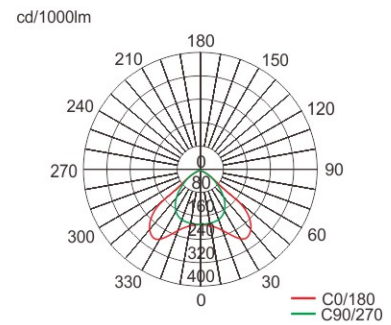
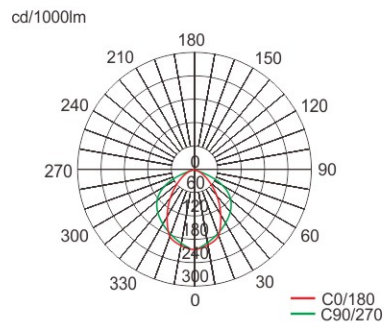
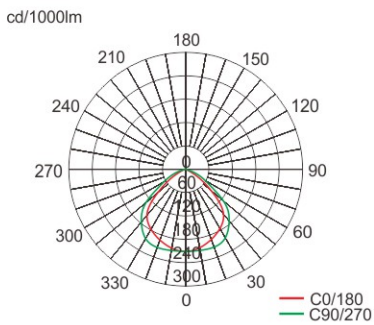

配光曲线
Light distribution curve

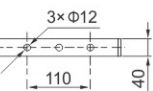
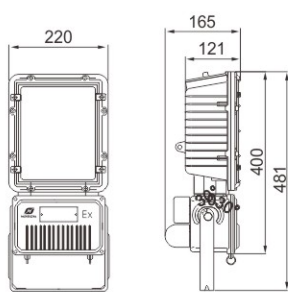

HRT53-L150

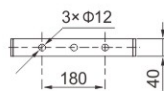
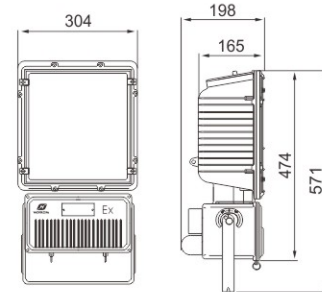

HRT53-L250

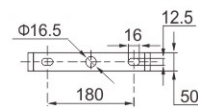
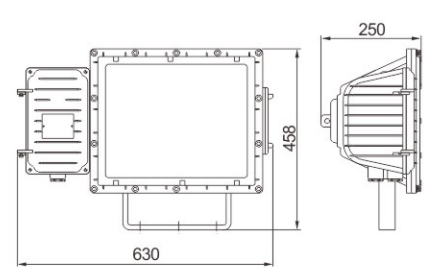

HRT53-L400